

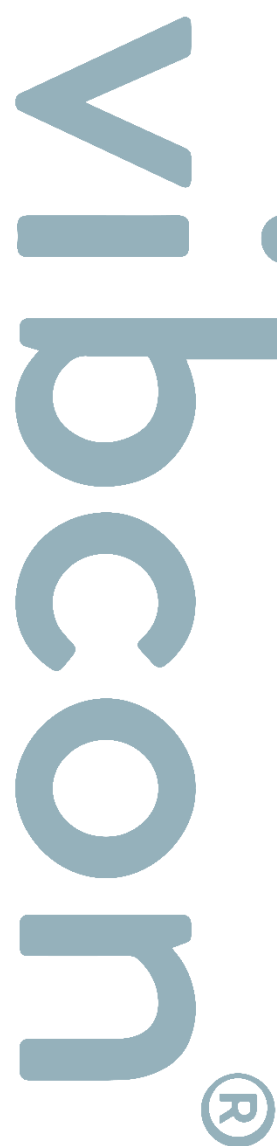

VIB SB

Rubber-metal dampers

Index



Information.....1



Dimensions.....1



Physical analysis.....2



Assembly.....3



Graph: Static/Dynamic.....4

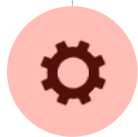

Applications.....7



Information

The rubber-metal dampers SB VIB are intended for machinery vibration mounts, which have the following features:

- Preferably radial vibration mode rather than axial
- Sudden starts and stops..
- Therefore, its particular hemispherical or conical geometry allows dynamic behavior the same in any direction.
- Each model comes in three ranges of hardness, giving this series a diverse range of point loads to bear.

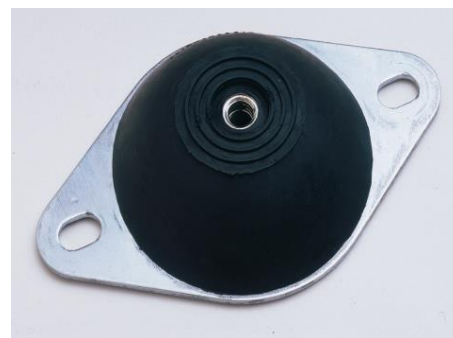

Dimensions

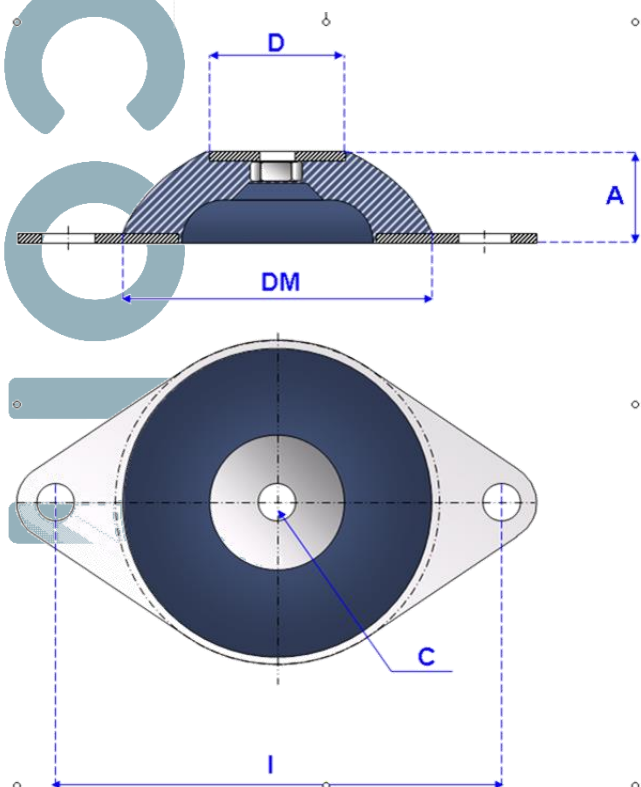

Model Vibcon	Dimensions in mm.					
	A	C	D	DM	I	J
VIB SB 40	18	M6	18.66	40	52	64
VIB SB 60	22	M-6	28	60	76	90
VIB SB 80	25	M8	37.33	80	100	120
VIB SB 100	24	M-10	58	96	124	148
VIB SB 150	40	M-14	80	150	186	213
VIB SB 250	42	M-16	128	200	240	280



Physic analysis

Los valores mínimos de carga y flecha son un 25% de los valores máximos indicados

Model Vibcon	COMPRESSION STATIC LOAD				
	MINIMUM ARROW mm.	MINIMUM LOAD daN.	MAXIMUM ARROW mm.	MINIMUM LOAD daN.	OPTIMAL LOAD ZONE daN.
VIB SB 044	1	1	2	4	0.5-3.2
VIB SB 046	1	2	2.5	10	0.5-8
VIB SB 047	1	3	3	15	0.5-12
VIB SB 064	1	3	3	15	5-12
VIB SB 066	1	5	3	25	8-20
VIB SB 067	1	10	3	50	15-40
VIB SB 084	1	11	4.5	45	1-36
VIB SB 086	1	20	4.5	80	1 – 70
VIB SB 087	1	30	4	120	1 – 110
VIB SB 104	1	18	5	90	27 – 72
VIB SB 106	1	32	5	160	48 – 130
VIB SB 107	1	44	5	220	66 – 180
VIB SB 154	2	26	8	130	39 – 110
VIB SB 156	2	50	8	250	75 – 200
VIB SB 157	2	70	7	350	105 – 300
VIB SB 254	2	100	8	500	150 – 400
VIB SB 256	2	160	9	800	240 – 650
VIB SB 257	2	240	10	1200	360 – 1000

Modelo Vibcon	SHEAR STATIC LOAD				
	MINIMUM ARROW mm.	MINIMUM LOAD daN.	MAXIMUM ARROW mm.	MINIMUM LOAD daN.	OPTIMAL LOAD ZONE daN.
VIB SB 64	1	1	3	3	1.5 - 2.5
VIB SB 66	1	1	3	5	1.5 - 4
VIB SB 67	1	1	3	10	1.5 – 8
VIB SB 104	1	2	3	18	2.5 – 16
VIB SB 106	1	3	3	32	2.5 – 28
VIB SB 107	1	4	3	44	3 - 40

Note: 1 daN. = 1,02 kp = 1,02kgf

These values are unique products VIBCON. They have been obtained by dynamometer tests and therefore are not valid for any other product. A request is enclosed test certificate.



Assembly

Shear Assembly

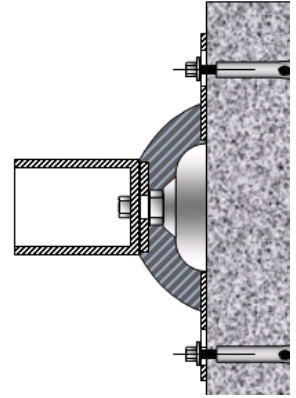
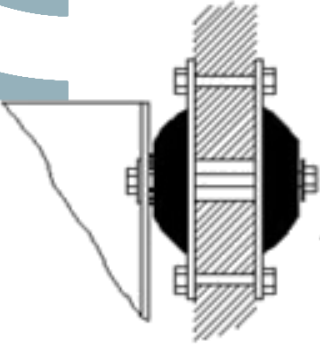

COMPRESSION assembly supported either by floor fixing

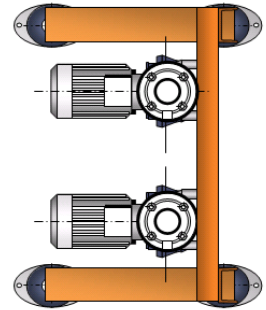
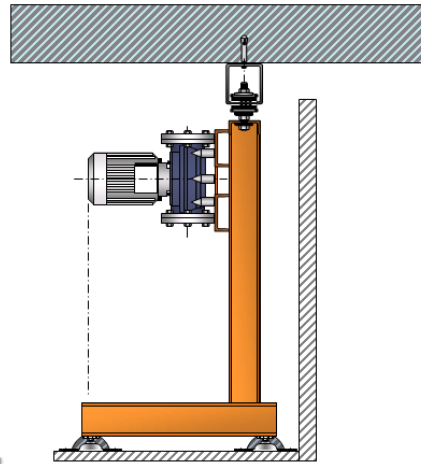
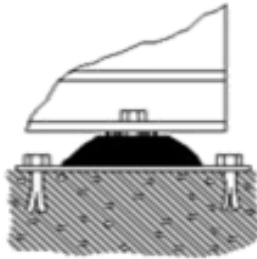
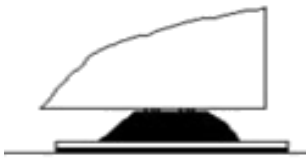

COMPRESSION assembly supported either by floor fixing

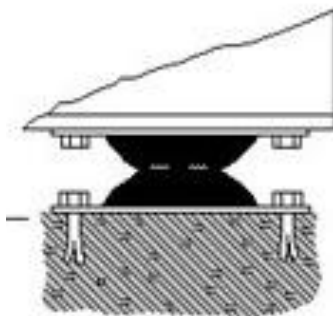



Graph: Static/Dynamic

Dynamometer tests are performed to determine the hysteresis curve (charge-discharge).

VIB SB100



Vibcon
Vibroacústica, control y aislamiento, S.L.

MODELO: **BM-100 6/0**

PARAMETROS: **s/norma VIBCON**

FECHA: 7/08/03

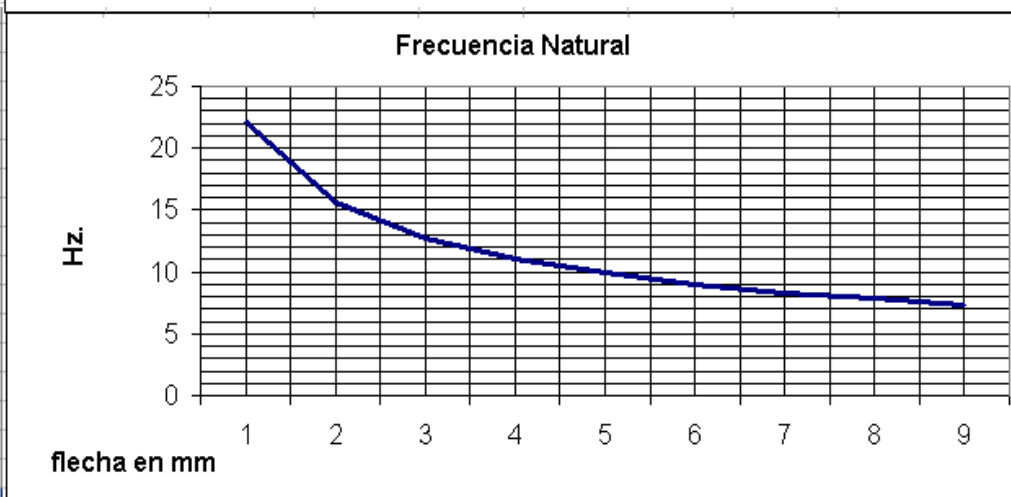
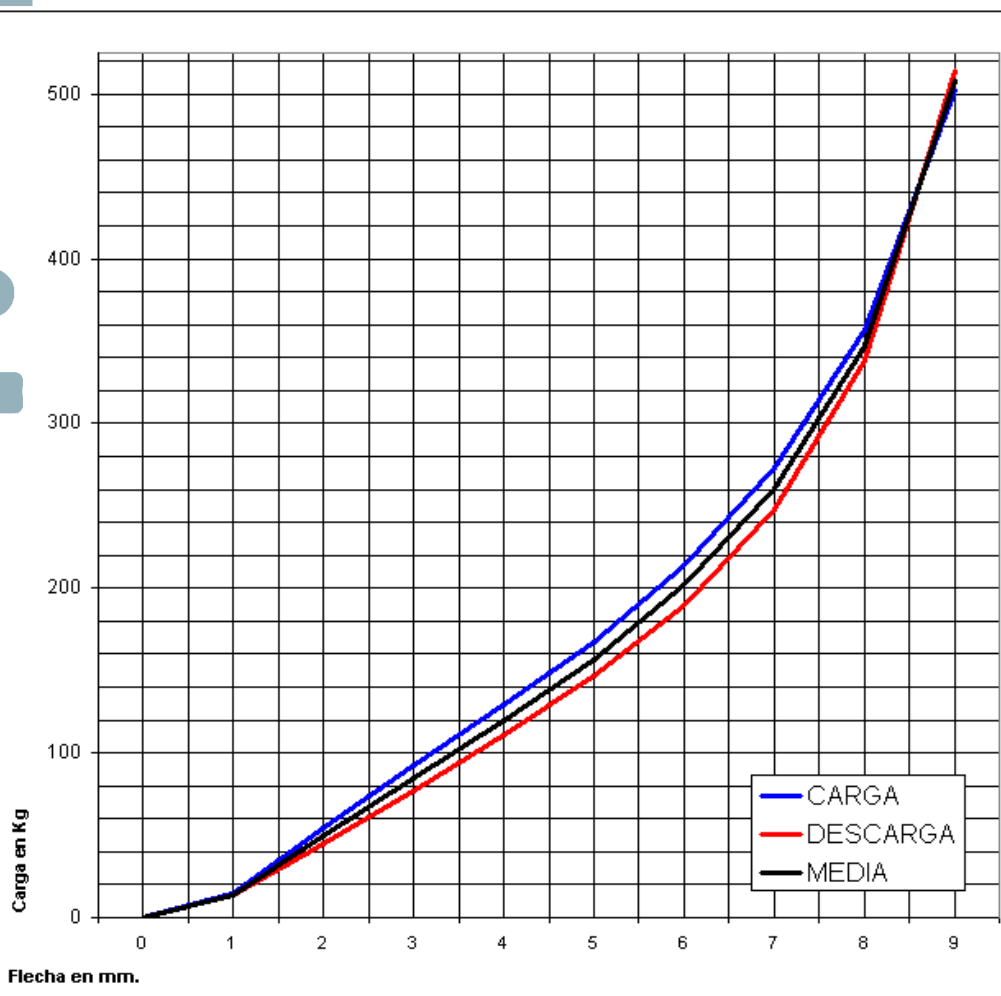

VIB SB100



Vibcon

Vibroacústica, control y aislamiento, S.L.

MODELO: **BM-150 6/0**

FECHA: 28/05/06

PARAMETROS: **s/norma VIBCON**

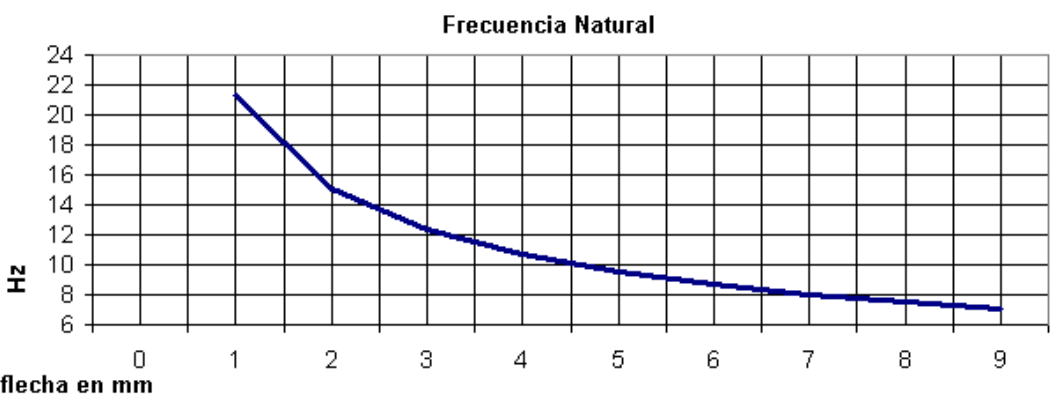
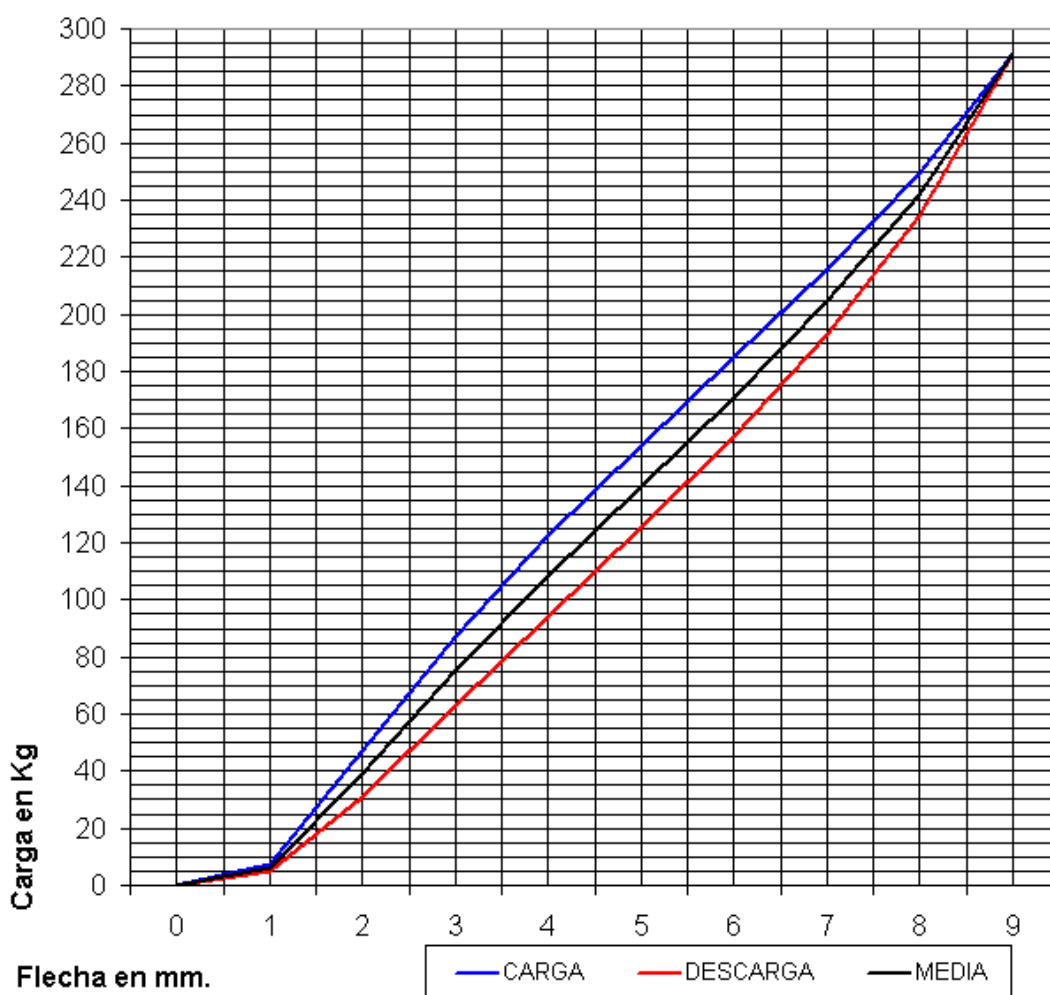



MODELO: **BM-150 7/0**
PARAMETROS: **s/norma VIBCON**

FECHA: **3/06/03**

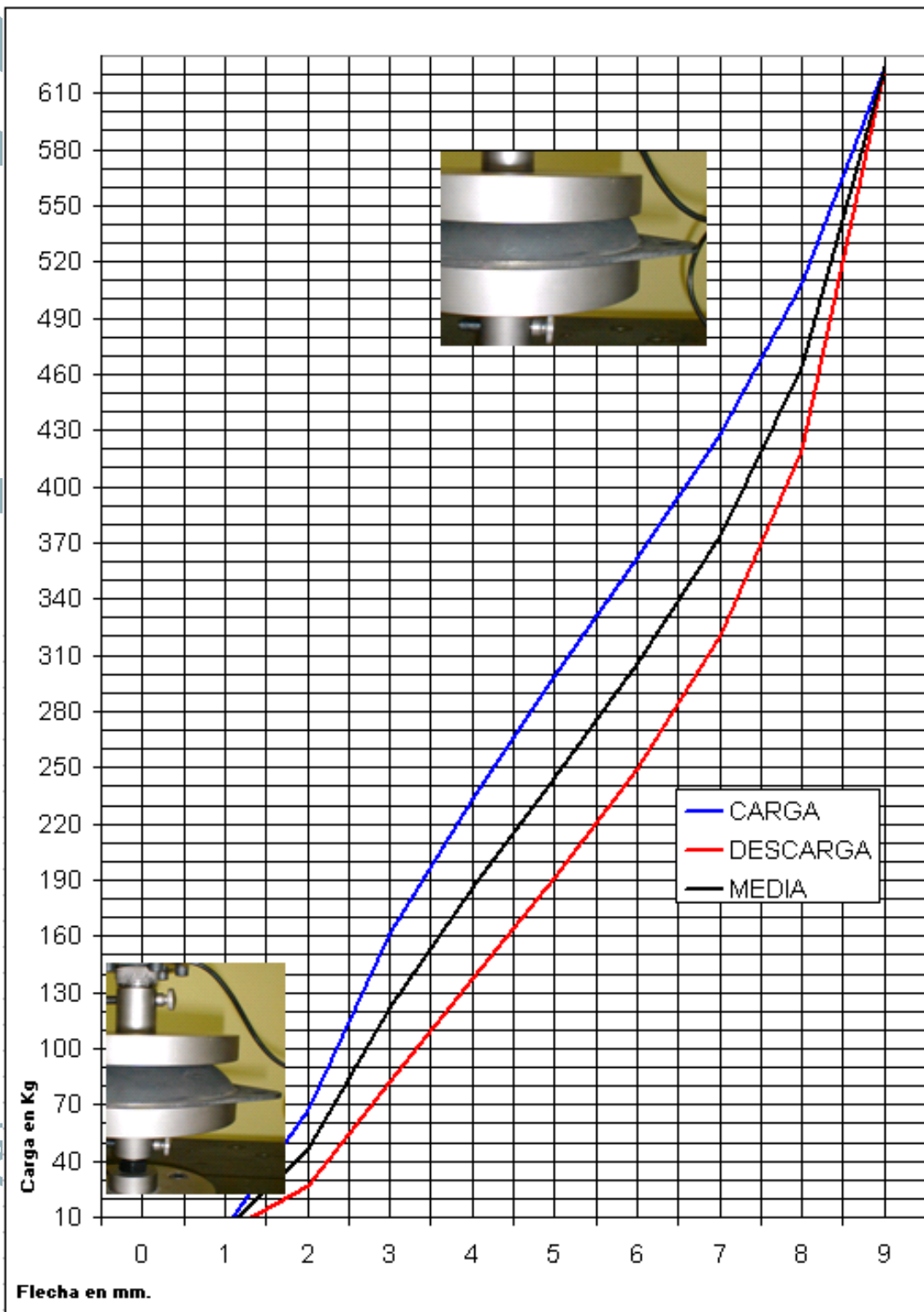



Applications

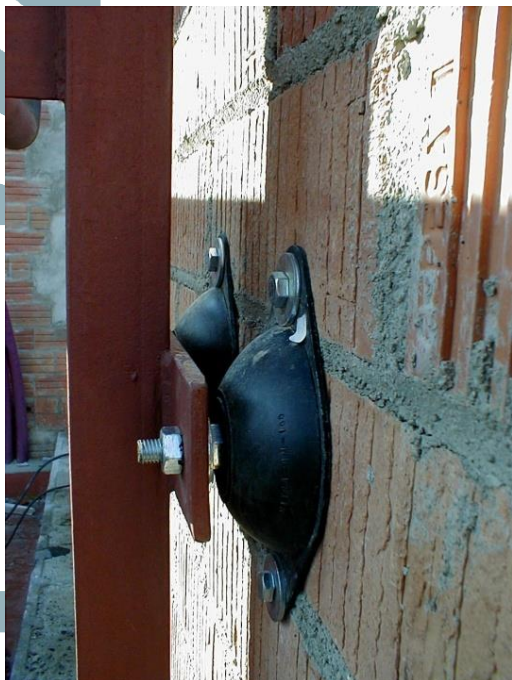

- Support for driving water pumps
- Vertical pipe sections
- Floating benches

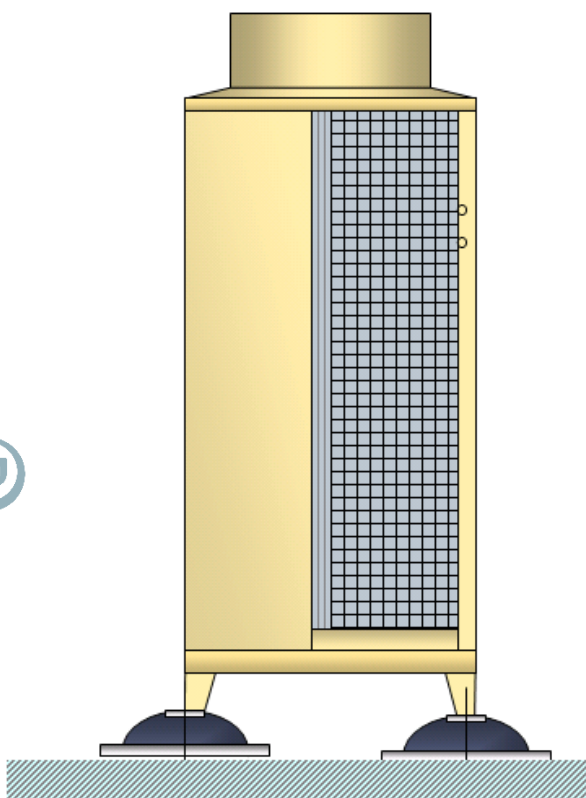

- Vertical air conditioners
- Airbox
- Compressors

The logo consists of a white graphic element on the left, composed of several curved, parallel lines that sweep upwards and to the right, resembling a stylized sound wave or a fan. To the right of this graphic is the word "vibcon" in a bold, lowercase, sans-serif font. A registered trademark symbol (®) is positioned at the top right of the letter "n".

vibcon[®]

Vibroacústica Control y Aislamiento S.L.